

Invisible Speaker Installation and User's Manual

1. Cut out opening before installing the speaker, make sure speaker cable is exposed and easily to be get access.

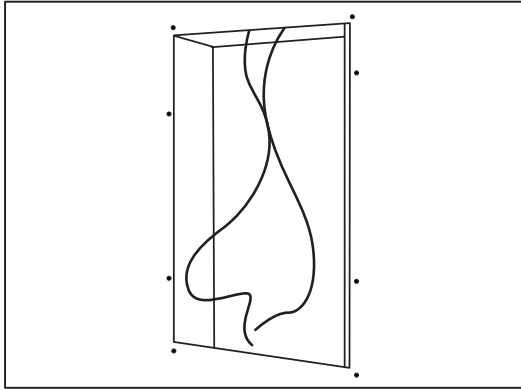

2. Peel off corresponding adhesive backing.

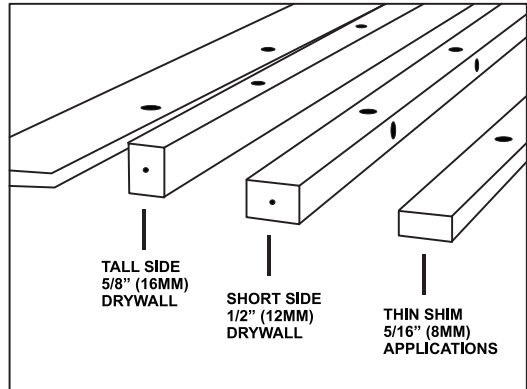

3. Select the appropriate shim for the application.

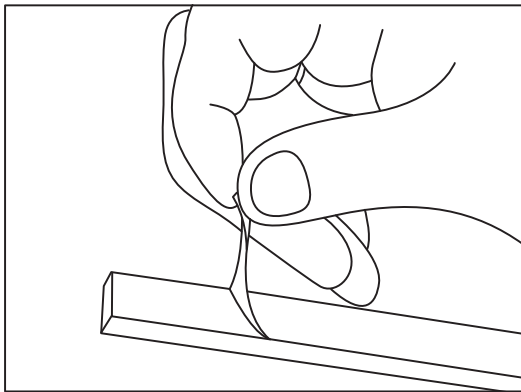

4. Press shim firmly into position, aligning screw holes.

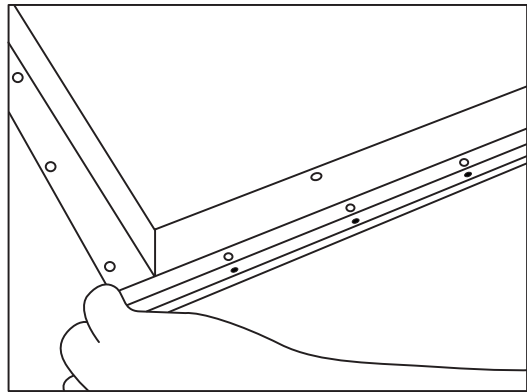

5. Connect speaker cable to the correct speaker terminal.

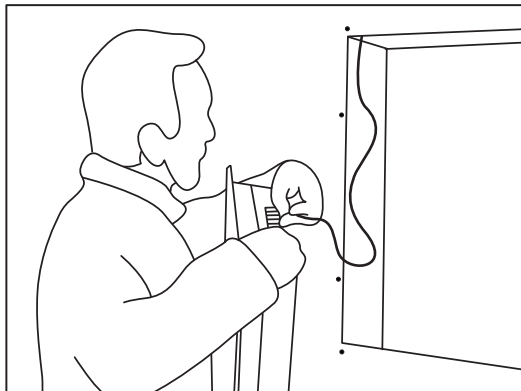

6. Insert speaker into opening.

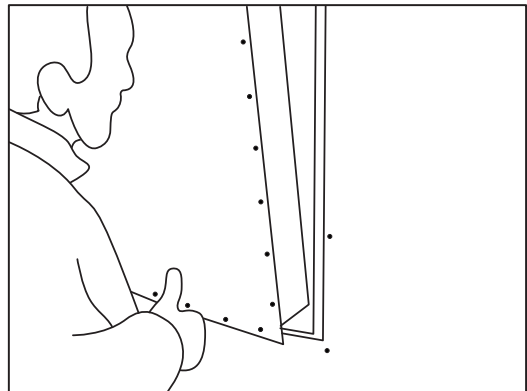

7. Secure speakers with screws on each side.

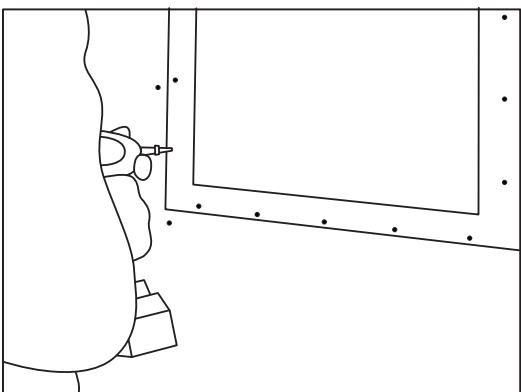

8. Fill the gap between speaker and wall with hot mud. Feature all edges.

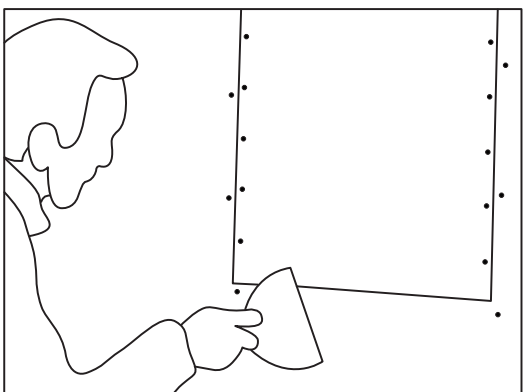

9. Allow hot mud to set slightly before applying mesh tape.

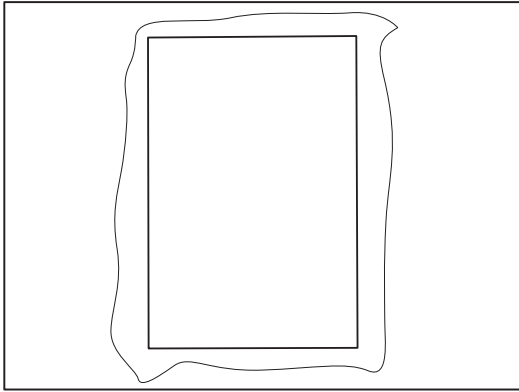

10. Mash tape over the wall seams. Overlap tape slight.

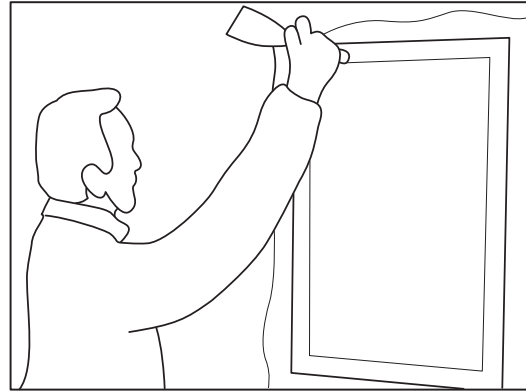

11. Allow hot mud to fully cure or harden.

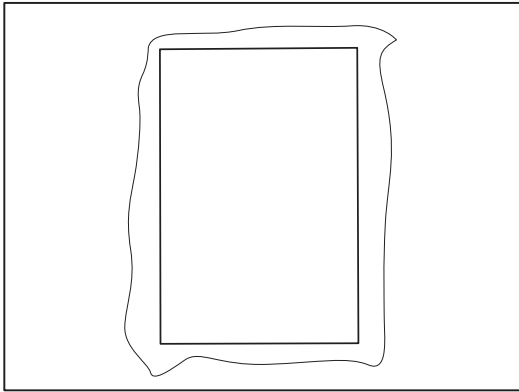

12. After hot mud has fully cured or hardened, begin to build layer of compound around the speaker.



13. Feature all the surfaces. Allow the first coat to fully cure or harden.

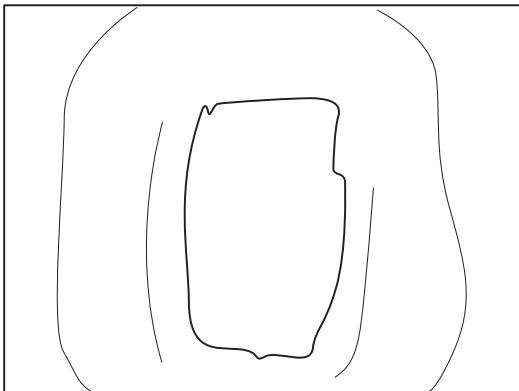

14. Start a second coat covering the entire surface, attention that compound buildup on the active surface of the speaker should not exceed 3mm.

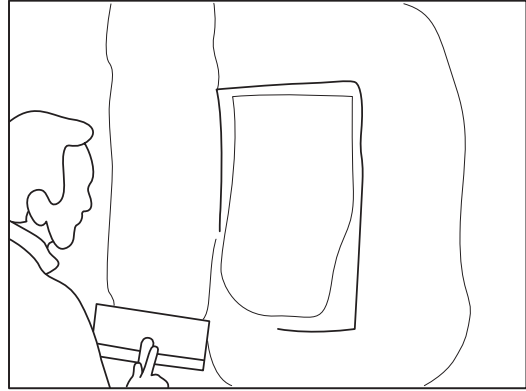

15. Detail the compound to minimize tool marks. Build more coats as necessary to achieve perfect surface.

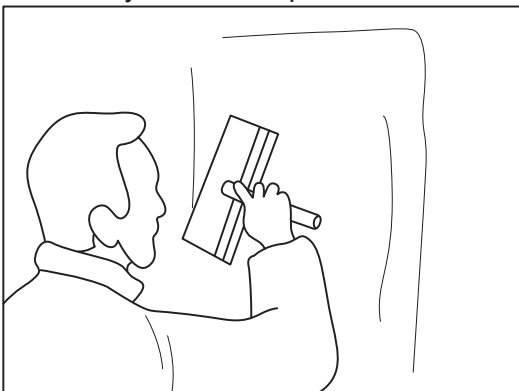

16. After final coat is dried, use a manual pole sander on the entire wall. Wall surface should show no signs of the speaker.

